

PROCESS DEVELOPMENT & CONTROL LLC

1075 MONTOUR WEST INDUSTRIAL PARK
CORAOPOLIS, PENNSYLVANIA 15108
PHONE (724) 695-3440 ♦ FAX (724) 695-8635

**INSTALLATION, OPERATING AND MAINTENANCE INSTRUCTIONS FOR
2"-14" EXCEL SERIES 40 WAFER STYLE VALE WITH LOCK LEVER FOR HIGH
TEMPERATURES**

RELEASED: 04/11/95	ID #	APPROVED BY:	DATE:
REV.: ADD FILL IN DRGW. NO. 04/18/96	EIB 1.1.1.6	SALES:	
Added EIB 12.1 3/14/03		ENGINEERING:	

TABLE OF CONTENTS

DRAWING NUMBER _____

STORAGE AND HANDLING OF VALVE ASSEMBLIES EIB 12.1

WAFER STYLE BUTTERFLY VALVE INSTALLATION INSTRUCTIONS
..... EIB 1.1

DETAILS OF LOCKLEVER EIB 2.1.1

OPERATION & MAINTENANCE OF WAFER STYLE BUTTERFLY VALVES
..... EIB 9.0

REPACKING PROCEDURE EIB 10.4

PROCESS DEVELOPMENT & CONTROL LLC

1075 MONTOUR WEST INDUSTRIAL PARK
CORAOPOLIS PENNSYLVANIA 15108
PHONE (724) 695-3440 ♦ FAX (724) 695-8635

STORAGE AND HANDLING OF VALVE ASSEMBLIES

RELEASED: 3/12/2003	ID #	APPROVED BY:	DATE:
REV.: Revised 11/5/12, added storage reqm'ts 3.1	EIB 12.1	SALES:	
		ENGINEERING: R.N. Koch	11/5/2012

TABLE OF CONTENTS

INSPECTION PROCEDURE	Section 1, Page 1
HANDLING PROCEDURE	Section 2, Page 1
STORAGE PROCEDURE	Section 3, Page 1

PROCESS DEVELOPMENT & CONTROL LLC

ENGINEERING INSTRUCTION BULLETIN

EIB.: 12.1 ORIGINAL DATE: 3/12/2003 PAGE: 1 of 1 REVISION: Revised DATE: 11/5/12

TITLE: STORAGE AND HANDLING OF VALVE ASSEMBLIES

1. INSPECTION PROCEDURE

1.1 Valve assemblies should be inspected upon receiving and prior to installation. Carefully remove the valve assembly from its shipping crate or box. Valve and accessories should be inspected for damage. The valve sealing surfaces should be inspected for scratches.

2. HANDLING PROCEDURE

2.1 Never lift or move the valve assembly using the disc, valve seat (bore), shafts or packing follower / nut as a pressure point.

2.2 Never lift or move the valve assembly by using the actuator, positioner, tubing or other attached accessories.

2.3 It is recommended that lifting straps (instead of chains or hooks) be used around the valve stem neck and thru the flange bolt holes for pressure points.

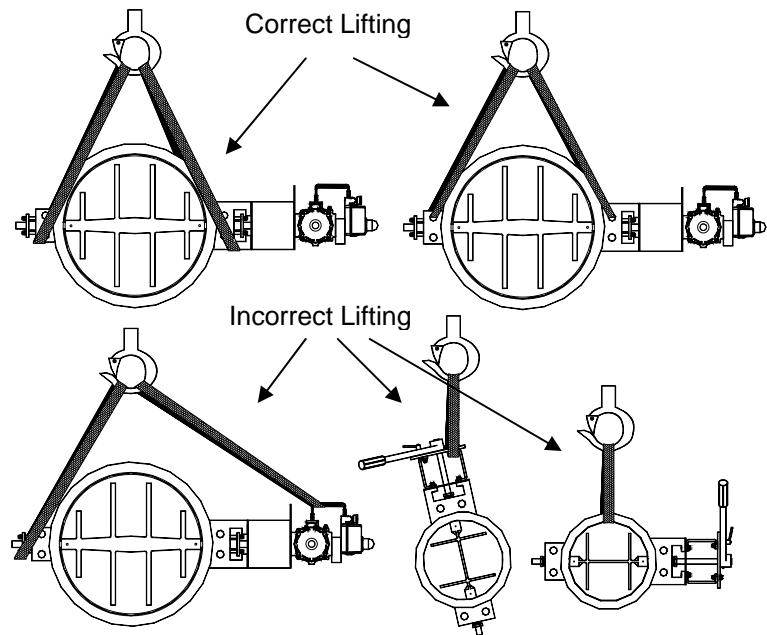

3. STORAGE PROCEDURE

3.1 Valve assemblies should be kept in a clean, heated, weather tight (dry), well-ventilated, storage facility with flooring that seals against dust and dirt and will not be subject to flooding. **Climate controlled storage of cast iron or steel damper-valve assemblies is highly recommended due to the exposed bare metal sealing surfaces necessary for operation (gasket faces, disc to body seats, valve bores, etc.) and due to the electronics and controls many times included.** If outdoor storage is unavoidable for short periods of time, support the valve assembly off of the ground and protect with a watertight cover on all sides.

3.2 Valve assemblies should be stored off of the floor on suitable skids, pallets or racks and protected from dirt, debris and exposure to direct sunlight, particularly to elastomer sealing surfaces.

3.3 Valve assemblies should be protected from rodents, insects or other creatures which can cause damage.

3.4 The proper use of racks, pallets, and handling equipment shall be used. The assemblies should be arranged so as to prevent damage to protruding accessories during storage.

3.5 Valve assemblies with electrical components, pneumatic tubing, positioners, actuators, and other accessories should be protected from impact.

3.6 Rubber seated valves should be stored with the disc slightly opened, (about 5°), if practical.

PROCESS DEVELOPMENT & CONTROL LLC
 1075 MONTOUR WEST INDUSTRIAL PARK
 CORAOPOLIS, PENNSYLVANIA 15108
 PHONE (724) 695-3440 ♦ FAX (724) 695-8635

WAFER STYLE BUTTERFLY VALVES INSTALLATION INSTRUCTIONS

RELEASED: 11-1-94	ID #	APPROVED BY:	DATE:
REV.:	EIB 1.1	SALES:	
		ENGINEERING:	

TABLE OF CONTENTS

INSTALLING WAFER STYLE BUTTERFLY VALVES PAGE 1

**PROCESS
PROCESS DEVELOPMENT & CONTROL LLC**

ENGINEERING INSTRUCTION BULLETIN

EIB.: 1.1

ORIGINAL DATE: 8/1/89

PAGE 1 OF 1

REVISION 2

Date: 12/16/91

TITLE: WAFER STYLE BUTTERFLY VALVE INSTALLATION INSTRUCTIONS

WARNING! VALVE MUST BE INSTALLED WITH SHAFT IN HORIZONTAL POSITION.

1. INSTALLATION

- 1.1. Remove valve assembly from box or crate with caution. Check assembly for possible damage during shipping.
- 1.2. Check alignment of pipe flanges before installation of valve. Poor alignment may cause installation and operation difficulties.
- 1.3. For valves not manually operated, which are received with disc in open position, it will be necessary to disconnect the power linkage and rotate disc to the closed position.
- 1.4. Valves may be installed with flow in either direction through the valve, but should be installed with the shaft in the horizontal position.
- 1.5. Gaskets may be installed at this time on valve faces or after valve has been positioned between flanges if desired.
- 1.6. Install butterfly valve between flanges using the four alignment holes. Install remaining bolts and tighten nuts evenly after valve has been centered and disc opens and closes without interference.
- 1.7. If it was necessary to disconnect power linkage in 1.3 open valve and reconnect linkage.
- 1.8. Make all necessary connections to actuator and accessories in accordance with manufacturers' recommendations and codes.

PROCESS DEVELOPMENT & CONTROL LLC

1075 MONTOUR WEST INDUSTRIAL PARK

CORAOPOLIS, PENNSYLVANIA 15108

PHONE (724) 695-3440 ♦ FAX (724) 695-8635

COMBINATION 10 POSITION AND INFINITE POSITION LOCKING LEVER

RELEASED: 11/01/94	ID #	APPROVED BY:	DATE:
REV.: 2 08/12/2000	EIB 2.1.1	SALES:	
		ENGINEERING:	

TABLE OF CONTENTS

ADJUSTMENT PROCEDURES FOR PDC 10-POSITION LOCKING AND INFINITE
THROTTLING LEVER

..... PAGE 1

PROCESS DEVELOPMENT & CONTROL LLC

ENGINEERING INSTRUCTION BULLETIN

EIB.: 2.1.1

ORIGINAL DATE: 11/01/94

PAGE 1 of 1

REVISION 2

Date: 08/12/2000

TITLE: ADJUSTMENT PROCEDURES FOR PDC 10-POSITION LOCKING AND INFINITE THROTTLING LEVER

2.1.1.1 LOOSEN WING NUT (ITEM #1) . NOTE: THERE IS NO NEED TO REMOVE THE WING NUT.

2.1.1.2 THE INDICATOR PLATE (ITEM #3) HAS 10 SLOTTED SECTIONS IN 10° INCREMENTS FROM "C" CLOSED, 0° OF DISC ROTATION, TO "O" FULLY OPEN, OR 90° OF DISC ROTATION. THE VALVE MAY BE LOCKED AT ANY ONE OF THESE 10 POSITIONS. PULL THE LOCKING BOLT (ITEM #5) AND FRICTION LOCK (ITEM #4) FORWARD SO THAT IT MOVES FREELY IN THE INDICATOR PLATE (ITEM #3). MOVE THE LEVER TO THE DESIRED POSITION, THEN PUSH THE LOCKING BOLT (ITEM #5) AND FRICTION LOCK (ITEM #4) BACK INTO THE APPROPRIATE SLOT.

-OR-

FOR APPLICATIONS REQUIRING FINER CONTROL, AN INFINITE RANGE OF DISC POSITIONS BETWEEN 0° AND 90° IS POSSIBLE. THIS MAY BE ACHIEVED BY PULLING THE LOCKING BOLT (ITEM #5) AND FRICTION LOCK (ITEM #4) FORWARD THEN SLIDING THE LEVER TO ANY DESIRED POSITION ON THE INDICATOR PLATE (ITEM #3).

2.1.1.3 TIGHTEN THE WING NUT (ITEM #1) TO THE LOCKING BOLT (ITEM #5) AND FRICTION LOCK (ITEM #4).

TABLE OF CONTENTS

1. WING NUT
2. LEVER ARM
3. INDICATOR PLATE
4. FRICTION LOCK
5. LOCKING BOLT

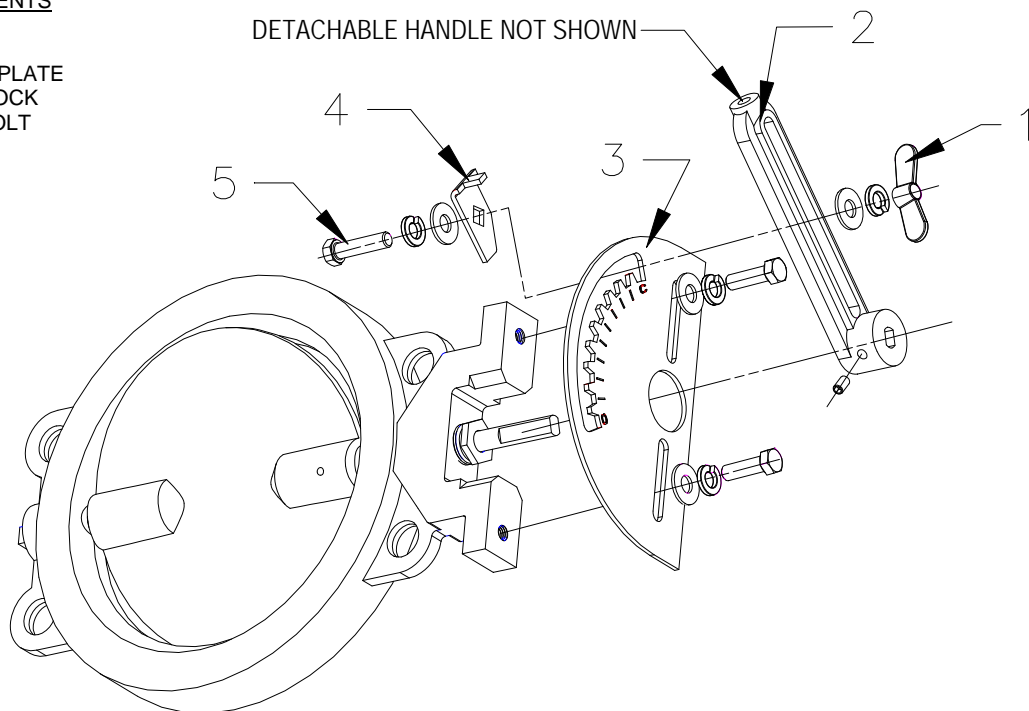

PROCESS DEVELOPMENT & CONTROL LLC

1075 MONTOUR WEST INDUSTRIAL PARK

CORAOPOLIS PENNSYLVANIA 15108

PHONE (724) 695-3440 ♦ FAX (724) 695-8635

OPERATION AND MAINTENANCE OF WAFER STYLE BUTTERFLY VALVES

RELEASED: 11-1-94	ID #	APPROVED BY:	DATE:
REV.: A CORRECTED TITLE 11-30-94	EIB 9.0	SALES:	
		ENGINEERING:	

TABLE OF CONTENTS

OPERATION AND MAINTENANCE..... PAGES 1 & 2

PROCESS DEVELOPMENT & CONTROL LLC

ENGINEERING INSTRUCTION BULLETIN

EIB NO.: 9.0 ORIGINAL DATE: 9/1/89 PAGE: 1 OF 2 REVISION: 2 DATE: 12/16/91

TITLE: OPERATION AND MAINTENANCE OF WAFER STYLE BUTTERFLY VALVE ASSEMBLIES

1. OPERATION

1.1. General

- 1.1.1. PDC wafer style butterfly valves are designed to provide long, dependable service with minimum maintenance, requiring only the possible adjustment of the packing gland after the valve has been installed.
- 1.1.2. The packing list should be carefully examined to determine the maximum operation and service conditions of the butterfly valve.

1.2. Determine Disc Position

- 1.2.1. PDC offers several shaft drive configurations depending on type of lever or actuator furnished. If the end of the shaft is saw cut, the saw cut will be in line with the disc edge.
- 1.2.2. Flats of flatted drive shafts will be in line with the disc edge.
- 1.2.3. Hexed drive shafts will have the end of the shaft saw cut in line with the disc edge.
- 1.2.4. Keyways on keyed drive shafts will be in line with the disc edge. (When keyways are not in line with disc edge, the end of the shaft will be saw cut. In this case the saw cut will be in line with the disc edge.)
- 1.2.5. Plain round drive shafts will have the end of the shaft saw cut in line with the disc edge.

1.3. Adjusting Packing Nut

- 1.3.1. The packing nut or follower tube has been adjusted prior to shipping. However, it may be necessary to readjust it when a system is started up.
- 1.3.2. If it is necessary to adjust the packing nut or follower, tighten $\frac{1}{4}$ turn. Operate for 15 minutes. If leakage persists after 15 minutes continue to tighten $\frac{1}{4}$ turn and operate for 15 minutes. (Repeat this process until leakage stops.)

PROCESS DEVELOPMENT & CONTROL LLC

ENGINEERING INSTRUCTION BULLETIN

EIB NO.: 9.0 ORIGINAL DATE: 9/1/89 PAGE: 2 OF 2 REVISION: 2 DATE: 12/16/91

TITLE: OPERATION AND MAINTENANCE OF WAFER STYLE BUTTERFLY VALVE ASSEMBLIES

2. MAINTENANCE

2.1. Lubrication

2.1.1. No routine lubrication of the standard PDC wafer style butterfly valve is required.

2.1.2. Valves that are furnished with lubrication fittings should be periodically lubricated as outlined in Table I and/or Table II.

TABLE I BUSHINGS, INBOARD

TEMPERATURE	ATMOSPHERE	GREASING INTERVAL
Up to 120° F	Clean	12 Months
Up to 210° F	Clean	6 months
Up to 150 ° F	Dirty	1 to 3 Months
Over 150° F	Dirty	Monthly
Any Temperature	Extreme Condition	Weekly

TABLE II BUSHINGS, OUTBOARD

SPEED	TEMPERATURE	ATMOSPHERE	GREASING INTERVAL
1-100 RPM	Up to 120° F	Clean	6 to 12 Months
500 RPM	Up to 150° F	Clean	2 to 6 months
1000 RPM	Up to 210 ° F	Clean	2 Weeks to 2 Months
1500 RPM	up to 210° F	Clean	Weekly
Any Speed	Up to 150° F	Dirty	1 Week to 1 Month
Any Speed	Over 150° F	Dirty	Daily to 2 Weeks
Any Speed	Any Temperature	Very Dirty	Daily to 2 Weeks

Grease: Use lithium based grease to a NLGI grade 2 consistency. This light viscosity, low torque grease is rust inhibited, water resistant, and has a temperature range of -30° F to +200° F with intermittent highs.

PROCESS DEVELOPMENT & CONTROL LLC

1075 MONTAUR WEST INDUSTRIAL PARK
CORAOPOLIS, PENNSYLVANIA 15108
PHONE (724) 695-3440 ♦ FAX (724) 695-8635

**REPACKING PROCEDURES FOR (50mm-350mm) 2" THRU 14",
EXCEL SERIES 40 WAFER STYLE VALVE**

RELEASED: 2/27/84	ID #	APPROVED BY:	DATE:
REV.: 4 DATE: 5/12/94	EIB 10.4	SALES:	
		ENGINEERING:	

TABLE OF CONTENTS

REPACKING PROCEDURE

..... PAGE 1

PROCESS DEVELOPMENT & CONTROL LLC

ENGINEERING INSTRUCTION BULLETIN

EIB.: 10.4

ORIGINAL DATE: 2/27/84

PAGE 1 of 2

REVISION 4

Date: 5/12/94

TITLE: REPACKING PROCEDURES FOR PDC EXCEL BUTTERFLY VALVES SERIES 40 2" THRU 14" VALVE SIZE (WIPER PACKING RING SUPPLEMENT PROCEDURE)

IMPORTANT: THERE ARE TWO STUFFING BOXES ON THE EXCEL SERIES 40 BUTTERFLY VALVE, THE STEPS BELOW SHOULD BE REPEATED FOR BOTH STUFFING BOXES.

- 10.4.1. REMOVE PACKING NUT (ITEM #7) USING A COUNTER-CLOCKWISE ROTATION (SEE NOTE 1, BELOW). SLIDE PACKING NUT BACK TO GIVE ADEQUATE CLEARANCE.
- 10.4.2. REMOVE ALL RINGS OF PACKING (ITEM #6) WITH FLEXIBLE PACKING PICK (SEE NOTE 1, BELOW).
- 10.4.3. THOROUGHLY CLEAN OUT PACKING GLAND HOLE AND REMOVE ALL RESIDUE.
- 10.4.4. REPACK VALVE WITH NEW PACKING (ITEM #6) BY STAGGERING ALL RING ENDS 90° APART. PACKING MATERIAL SHOULD NOT EXTEND INTO THE THREADED PORTION OF THE STUFFING BOX, (SEE NOTE 2, BELOW).
- 10.4.5. REPLACE PACKING NUT (ITEM #7) BY HAND TIGHTENING (CLOCKWISE). ONCE THE PACKING NUT IS HAND TIGHT, USE THE PACKING NUT WRENCH TO TIGHTEN PACKING NUT AN ADDITIONAL ½ TURN. THIS ADDITIONAL ½ TURN PAST HAND TIGHT SEATS THE RINGS OF PACKING (SEE NOTE 3, BELOW). **CAUTION: DO NOT OVER TIGHTEN PACKING NUT.**

NOTES:

1. A SPECIAL PDC REPACKING TOOL KIT CONSISTING OF A PACKING NUT WRENCH AND A FLEXIBLE PICK IS AVAILABLE FROM THE FACTORY. EMPLOYMENT OF THIS KIT WILL GREATLY FACILITATE THE REPACKING PROCEDURE AND ITS PURCHASE IS RECOMMENDED.
2. EACH REPACKING SET CONSISTS OF EXTRA RINGS OF PACKING. HOWEVER, IN MOST CASES, (5) FIVE RINGS OF PACKING SHOULD BE SUFFICIENT FOR EACH STUFFING BOX. (**DO NOT USE MORE RINGS THAN WERE REMOVED**).
3. IT MAY BE NECESSARY TO READJUST THE PACKING NUT WHEN THE SYSTEM IS STARTED UP. IF IT IS NECESSARY TO ADJUST THE PACKING NUT, TIGHTEN ¼ TURN. OPERATE FOR 15 MINUTES. IF LEAKAGE PERSISTS AFTER 15 MINUTES CONTINUE TO TIGHTEN ¼ TURN AND OPERATE FOR 15 MINUTES. (REPEAT THIS PROCESS UNTIL LEAKAGE STOPS). **CAUTION: DO NOT OVER TIGHTEN THE PACKING NUT.**

TABLE OF CONTENTS

1. VALVE BODY
2. DISC
3. POWER SHAFT
4. IDLE SHAFT
5. INBOARD BUSHING
6. PACKING
7. PACKING NUT
8. PIN

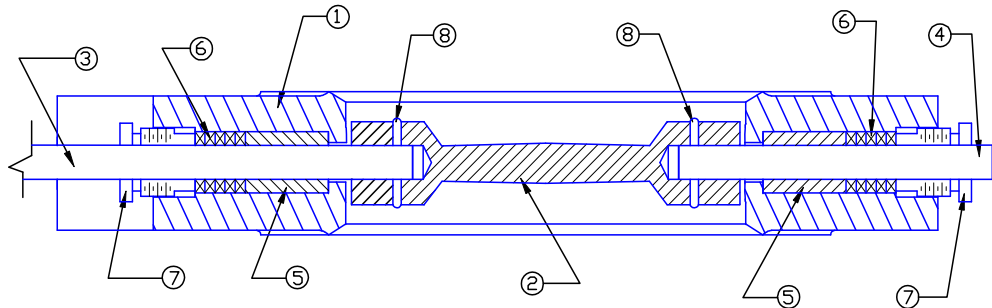

PROCESS DEVELOPMENT & CONTROL LLC

ENGINEERING INSTRUCTION BULLETIN

EIB.: 10.4

ORIGINAL DATE: 2/27/84

PAGE 1 of 2

REVISION 4

Date: 5/12/94

**TITLE: REPACKING PROCEDURES FOR PDC EXCEL BUTTERFLY VALVES SERIES 40
2" THRU 14" VALVE SIZE (WIPER PACKING RING SUPPLEMENT PROCEDURE)**

**THE FOLLOWING PROCEDURES ARE INTENDED FOR USE WHEN IT IS DESIRED
TO REPLACE ASSEMBLES WHICH INCLUDE A WIPER PACKING RING
(DIRTY SERVICE OR WASTE GATE VALVE ASSEMBLIES)**

- 10.4.6 BEFORE CLEANING PACKING GLAND HOLE AND REPACKING (10.4.3 & 10.4.4) FROM PREVIOUS PAGE, THE FOLLOWING SEQUENCE MUST BE COMPLETED.
- 10.4.7 REMOVE VALVE FROM PIPELINE. REMOVE THE TAPERED PINS (ITEM #8 FROM PREVIOUS PAGE), BY KNOCKING THEM OUT USING A HAMMER WITH A STARTER PUNCH.
- 10.4.8 REMOVE THE SHAFTS, POWERSHAFT AND IDLESHAFT (ITEMS #3 & 4), BY PULLING THEM THRU THE STUFFING BOX OPENING WHILE ALSO RELEASING AND REMOVING THE DISC.
- 10.4.9 REMOVE INBOARD BUSHING (ITEM #5) AND WIPER PACKING (ITEM #9) BY PUSHING THEM THROUGH THE STUFFING BOX CAVITY FROM THE BORE OF THE VALVE.
- 10.4.10 CLEAN PACKING GLAND AS IN PROCEDURE 10.4.3 FROM PREVIOUS PAGE.
- 10.4.11 REPLACE WITH A NEW WIPER RING (ITEM #9) AND NEW INBOARD BUSHING (ITEM #5) THEN CONTINUE WITH THE REPACKING PROCEDURE AS DESCRIBED IN 10.4.4 FROM THE PREVIOUS PAGE.

TABLE OF CONTENTS:

- 1. VALVE BODY
- 3. POWERSHAFT
- 5. INBOARD BUSHING
- 6. PACKING
- 7. PACKING NUT
- 9. WIPER PACKING RING

